

K

Test Equipment

INDEX

Test Equipment

Micro Hardness Testing Machines

Lineup of Hardness Testing Machines	K-2, 3
HM-101/112/113/122/123	K-4
HM-114/115/124/125	K-5
HM-211, 221	K-6, 7
AAV-500	K-8
MZT-500	K-9
HV-112/113/114/115	K-10
Optional Accessories	K-11

Rockwell Hardness Testing Machines

Rockwell Superficial Hardness Scales	K-12
HR-521/523	K-13
AR-20, ARK-600/601, ATK-600/601	K-14
Optional Accessories	K-15, 16

Portable Hardness Testing Machines

Hardmatic HH-411	K-17
Hardmatic HH-300	K-18, 19



Micro Hardness Testing Machines



Rockwell Hardness Testing Machines



Micro Zone Test System



Portable Hardness Testing Instruments



HARDMATIC HH-411



AAV-500



Lineup of Hardness Testing Machines

Hardness testing machines provide the simplest and most economical testing methods among many material testing machines, playing an important role in research activities, production activities, and commercial transactions. Mitutoyo offers a choice of standard hardness testing machines that are optimal for hard materials such as metals to soft materials such as plastic and rubber, as well as custom-designed testers such as in-line type automatic machines and labor-saving machines required on the shop floor.



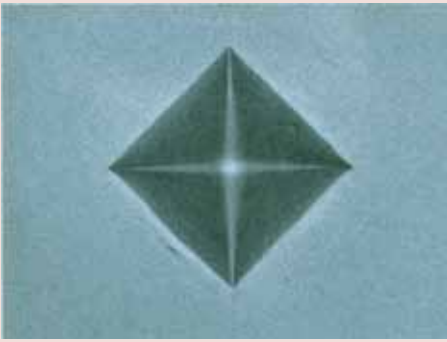

Polished Surface

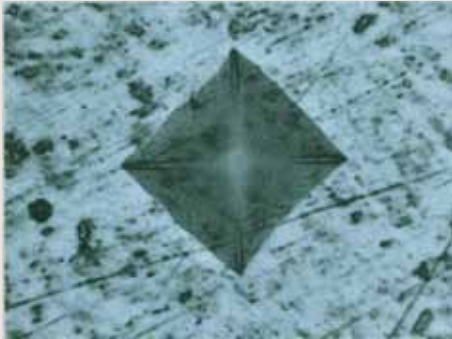

Scratched Surface

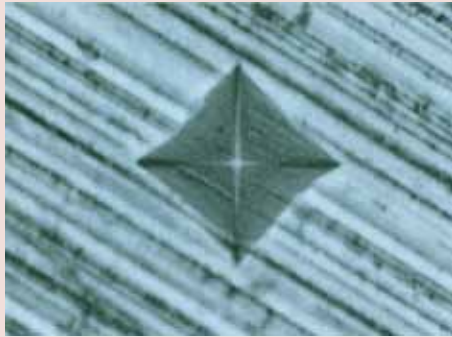

Ground Surface

Vickers Hardness

In the Vickers hardness test, a diamond pyramid indenter with a 136° angle between opposite faces is pressed into the specimen under a test force F (kgf). The hardness number (HV) is obtained by dividing F by the area, A (mm^2), of contact between the indenter and specimen. This area is calculated from the diagonal length, d (mm), of the indentation when the indenter is removed.

The Vickers hardness test is the most versatile hardness testing method of those that use different load settings. The Micro-Vickers hardness test, which accepts load settings of 1 kgf (9.807N) or less, is especially well suited for industrial production today, where accuracy requirements are increasing due to technology improvements.

Vickers hardness testing at loads of 1 kilogram and up is also known as heavy load Vickers or Macro Vickers. The other testing parameters are similar to lighter load vickers testing. This type of testing may be used to meet the requirements of international specifications or to replace Rockwell testing.

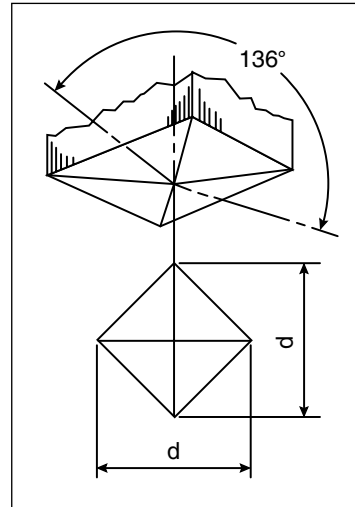

Knoop Hardness

In the Knoop hardness test, a diamond pyramid indenter, which has a rhombic base with included angles of $172^\circ 30'$ and 130° , is pressed onto the specimen under a test force F (kgf). The hardness number (HK) is obtained by dividing the test force F by the projected area, A (mm^2), of the indentation. This area is calculated from the longer diagonal length, d (mm), of the indentation when the indenter is removed.

The Knoop hardness scale is generally used when shallower depth indentations are required. Knoop hardness can be measured by installing a Knoop indenter on the Macro-Vickers hardness testing machine.

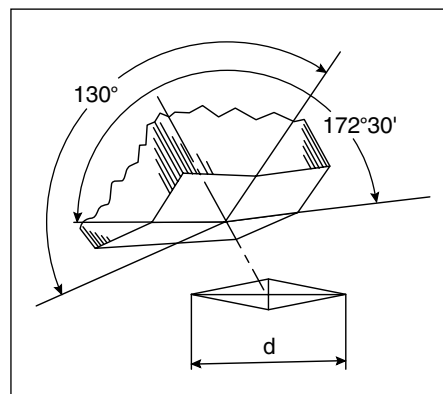

HM-101 / 112 / 113 / 122 / 123

SERIES 810 — Micro-Vickers Hardness Testing Machines

FEATURES

- A wide range of test force from 9.807 X10-3N to 9.807N (10gf to 1000gf) is available for measuring a various type of specimens. The load duration can be set in 1sec increments between 5 and 99sec*. The minimum reading of indentation is 0.01µm* and allows small indentations to be measured with high precision. *HM-112, HM-113
- Up to 3 Objective lenses and 1 or 2 indenters mounted on manual or motorized turret
- Eyepiece or CCTV
- Measuring Versions
- Camera port

HM-123



HM-113

Reduce individual differences in visual measurement with the TV monitor. The statistical calculation function reduces operation time.



HM-112

Digital display of measurement results and a statistical calculation function.



Touch screen type

HM-101



SPECIFICATIONS

Model	HM101	HM-112	HM-113	HM122 V	HM122 V/K	HM-123
Order No.	810-124A	810-126-07A	810-969-04A	810-127-04A	810-127-02A	810-990-02A
Supplied Indenter	VICKERS			VICKERS/KNOOP		
Test force*	98.07mN(10g), 245.2mN(25g), 490.3mN(50g), 980.7mN(100g), 1961mN(200g), 2942mN(300g), 4903mN(500g), 9807mN(1000g)					
Test force selection	Dial					
Loading control	Automatic (loading, duration, unloading)					
Load duration	5s-30s	5s to 99s (specified in 1-second increments)				
Loading Rate	60µm/sec.					
Objective Lenses	10x, 50x	10x, 50x		10x, 20x, 50x		
Turret	Manual			Motor Drive		
Measuring microscope total magnification	100x, 500x	100x, 500x		100x, 200x, 500x		
Video monitor screen Total Magnification	—	—	9" B/W 250x, 1250x	—	—	9" B/W 250x, 500x, 1250x
Filar eyepiece	10x	10x	—	10x	10x	—
Minimum reading	0.2mm	0.01µm				
Maximum Reading	140µm	700 / 140µm	500 / 100µm	700 / 350 / 140µm		500 / 250 / 100µm
Type	Micrometer Drum	Digital Optical Encoder				
XY stage Dimension	100 x 100mm	100 x 100mm				
Travel range	25 x 25mm	25 x 25mm				
Minimum reading	0.01mm	0.001mm				
Specimen Maximum height	95mm					
Maximum depth	150mm					
Display Function	Conversion; Hard: TENS, HS, HBS, HR15N, HR30N, HR45N, HRA, HRD, HRC, HK, HV, OFF Soft: TENS, HR15T, HR30T, HR45T, HRA, HRF, HRB, HRG, HK, HV, OFF OK/NG Judgement Curve correction: 0.01 to 200.00mm Data processing; Number to measurements 2 to 256 data Statistical list: N, Max., Min., Average, Range, High, Low, Good, Over, Under, SD(n-1), SD(n)					
Output	—	RS-232C, SPC, Centronics				
Dimensions	Main unit: W=16.1 x D=23.6 x H=23.2" (410 x 600 x 590mm) Display: W=6.5 x D=10.2 x H=4.1" (165 x 260 x 105mm)					
Weight	Main unit: 92.4 lbs. (42kg)					
Power supply	120V AC (±10%), 60 Hz					
Power consumption	20VA	60VA				

Optional Accessories

See Page K-11

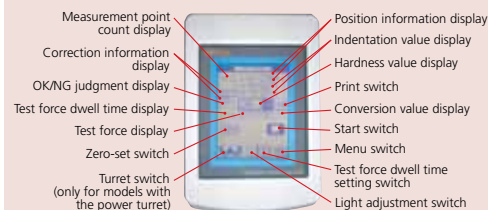

HM-114 / 115 / 124 / 125

SERIES 810 — Extended Range Micro-Vickers Hardness Testing Machines

FEATURES

- A wide range of test force from 4.903x10⁻³N to 19.61N is available for measuring a various type of specimens. The load duration can be set in 1sec increments between 5 and 99sec. The minimum reading of indentation is 0.01μm. Allowing small indentations to be measured with high precision.



HM-114

Optional Accessories

See page K-11

- 3 lenses for best resolution of indent size
- Manual or motorized turret
- Eyepiece or CCTV
- Measuring Versions
- Camera port

SPECIFICATIONS

Model	HM114	HM115	HM-124	HM125
Order No.	810-128A	810-998A	810-129A	810-975A
Standard Indenter	Vickers			
Test force	9.807mN(1gf), 19.61mN(2gf), 29.42mN(3gf), 4.903mN(0.5gf), 9.807mN(1gf), 19.61mN(2gf), 49.03mN(5gf), 98.07mN(10gf), 245.2mN(25gf), 490.3mN(50gf), 980.7mN(100gf), 1961mN(200gf), 2942mN(300gf), 4903mN(500gf), 9807mN(1000gf), 19610mN(2000gf)			
Test force selection	Dial > 25gf, Electronic 25gf and below			
Load control	Automatic (loading, duration, unloading)			
Load duration	5 to 99 sec (specified in 1-second increments)			
Loading rate	60 mic/sec > 25gf, 1, 3, 5, 33 mic/sec 25gf and below			
Objective lenses	10X, 50X, 100X			
Turret	Manual		Motorized	
Measuring microscope	100X, 500X, 1000X,		100X, 500X, 1000X,	
Total magnification				
Video monitor screen	250X, 1250X, 2500X		250X, 1250X, 2500X	
Filar Eyepiece	10X		10X	
Minimum reading	0.01μm			
Maximum Reading	700 / 140 / 70 μm	450 / 90 / 45 μm	700 / 140 / 70 μm	450 / 90 / 45 μm
Type	Digital Encoder			
XY stage	100 x 100mm			
Dimensions				
Travel range	25 x 25mm			
Minimum reading	0.001mm			
Specimen	3.74" (95mm)		3.54" (90mm)	
Maximum height				
Maximum depth	5.9" (150mm)		3.94" (100mm) from center of in denter shaft	
Display functions	Conversion; Hard: TENS, HS, HBS, HR15N, HR30N, HR45N, HRA, HRD, HRC, HK, HV, OFF Soft: TENS, HR15T, HR30T, HR45T, HRA, HRF, HRB, HRG, HK, HV, OFF OK/NG Judgement Curve correction: 0.01 to 200.00mm Data processing; Number to measurements 2 to 256 data Statistical list: N, Max., Min., Average, Range, High, Low, Good, Over, Under, SD(n-1), SD(n)			
Output	RS-232C, Centronics, SPC			
Dimensions (WxDxH)	16.1 x 23.6 x 23.2" (410 x 600 x 590mm)			
Main unit only				
Weight	42kg			
Power supply	120V AC (±10%) 60Hz			
Power consumption	20VA			

Touch screen type

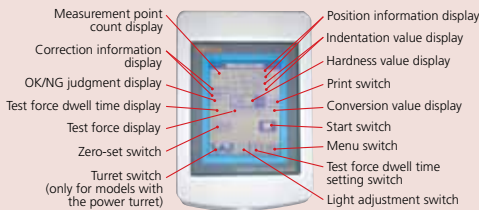

HM-211 / 221

SERIES 810 — Micro Hardness Testing Machines

FEATURES

- The latest electromagnetic force motor used in the loading mechanism enables the test force to be freely selected (see test force specifications over the wide range of 0.4903mN to 19810mN. It is also possible to freely set the time for loading and load dwell time. Now your desire for absolute control over the indentation size in Vickers hardness testing can be satisfied. The HM-200 series always offers the test force most appropriate for the specimen material and shape.
- It is possible to perform not only the Vickers hardness test but also a fracture toughness test on ceramics.
- The objectives used enable a very comfortable working distance between the objective and the specimen surface. This greatly reduces the possibility of collision between the specimen and the objective during focusing operations. (e.g. 1.1mm for 50X objective)
- The contrast that is most appropriate for the magnification of the objective can be obtained by manipulating the variable aperture stop in the illumination unit. This makes the indentations clearly visible, leading to less variation and reducing the chance of error when measuring the diagonal lengths.



HM-211



Power turret with 2 indenter mounts and 4 objective mounts (manual operation possible)

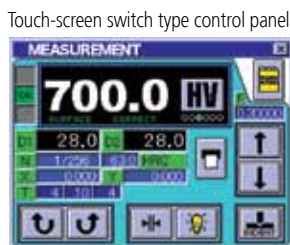

Touch-screen switch type control panel

SPECIFICATIONS

Model No.	HM-211					HM-221										
Order No.	810-352A					810-353A										
Fixed test force	mN	98.07	196.1	294.2	490.3	980.7	0.4903	0.9807	1.961	2.942	4.903	9.807	19.61	29.42	49.03	98.07
	gf	10	20	30	50	100	0.05	0.1	0.2	0.3	0.5	1	2	3	5	10
	mN	1961	2942	4903	9807		196.1	294.2	490.3	980.7	1961	2942	4903	9807	19610	
	gf	200	300	500	1000		20	30	50	100	200	300	500	1000	2000	
Arbitrary test force (One type of setting can be saved.)	Test force of 980.7mN or less can be set in increments of 9.807mN					Only a test force of 0.4903mN is available below 0.9807mN.										
	Test force of 980.7mN or more can be set in increments of 98.07mN.					Test force of 0.9807mN or more and below 9.807mN can be set in increments of 0.9807mN.										
						Test force of 9.807mN or more and below 980.7mN can be set in increments of 9.807mN.										
Test force control	Force generation by electromagnetic and automatic control (load, dwell, unload)															
Control unit	Touch-screen type					Touch-screen type										
Video monitor	—															
Indenter/objective turret	Motor driven and manual operation					Motor driven and manual operation										
Indenter mounts	2 (Vickers indenter is standard accessory)					2 (Vickers indenter is standard accessory)										
Objective mounts	4 (10X and 50X are standard accessories)					4 (10X, 50X and 100X are standard accessories)										

Technical Data

Test force range:	HM-211: 98.07mN to 980.7mN (9.807mN increments) 980.7mN to 9807mN (98.07mN increments)
HM-221:	0.4903mN 0.9807mN to 9.807mN (0.9807mN increments) 9.807mN to 980.7mN (9.807mN increments) 980.7mN to 19610mN (98.07mN increments)
Test force generation:	Electromagnetic
Load control:	Automatic (load, dwell, unload)
Load dwell time:	1 - 999 sec (1 sec increment)
XY stage	
Stage size:	100x100mm
Travel range:	25x25mm, with digimatic micrometer heads
Resolution:	0.001mm
Max. specimen height:	133mm
Max. specimen depth:	160mm (from the center of indenter)
Indenter/objective turret:	Motor driven and manual operation
Indenter mounting:	2 positions
Objective mounting:	4 positions
Optical path:	2-way (measurement / exposure)
Resolution:	0.01μm
Data output:	RS-232C, Digimatic code (SPC) and Centronics
Power supply:	100/120/220/240V AC, 50/60Hz
Dimensions (W x D x H):	400x640x600mm
Mass:	43kg

Optional Accessories

- 19BAA061:** Diamond indenter for Knoop (HM-211)
- 810-017:** Vise (max. opening: 100mm)
- 810-013:** Specimen (thin plate) holder
- 810-085:** Adjustable specimen (thin plate) holder
- 810-014:** Specimen (wire) holder
- 810-015:** Specimen (wire or ball) holder
- 810-019:** Specimen tilting holder
- 810-020:** Universal specimen holder
- 810-084:** Rotatable universal specimen holder
- 810-018:** Rotary table
- 810-622:** Printer (DPU-414)
- 19BAA157:** Printer paper (10-roll set)
- 19BAA266:** Connecting cable for printer
- 264-504:** DP-1VR
- 09EAA082:** Printer paper for DP-1VR (10-roll set)
- 936937:** SPC cable (1m)
- 965014:** SPC cable (2m)
- 19BAA001:** Hardness test block (100HV)
- 19BAA002:** Hardness test block (200HV)
- 19BAA003:** Hardness test block (300HV)
- 19BAA004:** Hardness test block (400HV)
- 19BAA005:** Hardness test block (500HV)
- 19BAA006:** Hardness test block (600HV)
- 19BAA007:** Hardness test block (700HV)
- 19BAA008:** Hardness test block (800HV)
- 19BAA009:** Hardness test block (900HV)
- 19BAA010:** Hardness test block (40HV)
- 810-641:** Vibration damping stand
- 11AAA002:** EXPACK data processing program

Consumable Parts

- 19BAA207:** Illumination lamp (1 pc.)

SYSTEM UPGRADE DIAGRAM

Video camera unit: 810-354A

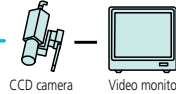

When integrated with the HM200 series, this unit can reduce operator errors in measurement made by eye.

Auto-measuring unit: 810-355-1

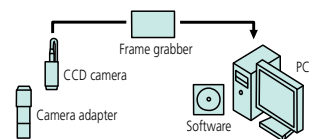

When integrated with the HM200 series, this unit helps reduce operator errors in measurement as it automatically measures the indentation diagonal and calculates the hardness value.

*PC system is optional

Auto-position unit: 810-356A

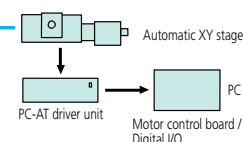

When integrated with the HM200 series combined with the auto-measuring unit, this unit can achieve both enhanced measurement efficiency and reduced measurement variation due to operator errors at the same time, thanks to the automatic indentation reading function and the automatic stage control function which is helpful for multiple point measurement of hardness.

Auto-focus unit*: 810-357

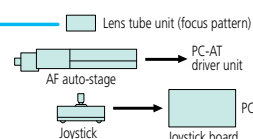

When integrated with the HM200 series combined with the auto-measuring unit and the auto-position unit, this unit allows all the necessary operations of hardness testing to be automatically and speedily performed.

* Factory-installed option

Heated Specimen Table HST-250: 810-870

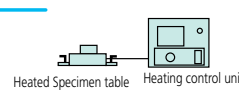

Hardness testing can be performed by heating the specimen to a maximum of 250°C.

Note

- When building in the video camera unit, remove the eyepiece unit of the measuring microscope (standard accessory). If the Auto-measuring unit is added, it will be exclusively used in place of the measuring microscope or video camera unit. For the exclusive use of the Auto-measuring unit or video camera unit, an optional camera power unit (Order No. **19BAA360**) is required. If the Auto-focus unit is added, the focus line is visible within the view field of the measuring microscope.
- The XY stage (digital type, standard accessory) is dismantled if the Automatic XY stage is to be used. Therefore, if the Auto-position unit is added and only the hardness tester is used, XY position data cannot be obtained.

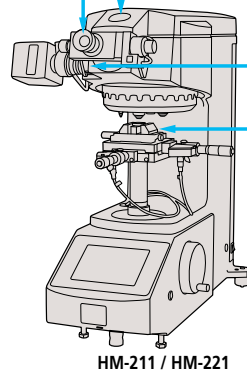

HM-211 / HM-221

With video camera unit



With auto-measuring unit



With auto-position unit



With auto-measuring unit, auto-position unit and auto-focus unit



AAV-500

SERIES 810 — Automatic Vickers Hardness Testing System

FEATURES

It can perform all operations required in the Vickers hardness test and Knoop hardness test such as loading, turret indexing,

focusing, indentation dimension detecting, and measurement position movement in full automatic, so it is optimal for labor saving requirements of your test environment.



AAV-501

- An indentation dimension automatic detecting time of 0.3 seconds is achieved (when a PC with recommended specifications is used), which dramatically improves operation efficiency.
- Detecting reproducibility of $\pm 0.5\%$ is achieved (For objective lens 50X, diagonal line 11 to 45mm, and 500HV), which provides reliable and stable test results.
- All operations from test condition setting to test result analysis can be performed on a Windows PC. In addition, data processing for the test results can be performed by using spreadsheet software.

The AAV-500 Series reduces individual differences in impression dimension measurement in the Vickers hardness test by adopting special image analysis technologies. In addition, improved precision and high speed have been realized with a detecting time of 0.3 seconds.

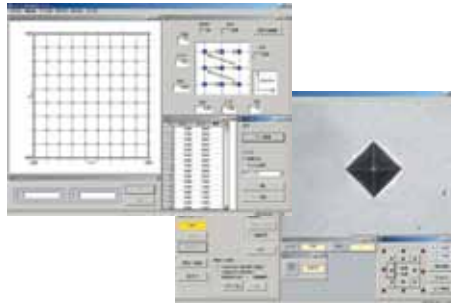

SPECIFICATIONS

Model No.	AAV-503	AAV-504
Order No.*	810-727A	810-728A
Test force range	1.961 - 196.1N (200gf - 20kgf)	9.807 - 490.3N (1kgf - 50kgf)
Test force switching	Manual	Manual
Objective	10X / 20X	10X / 20X
Measurable indentation size	40 - 400 / 20 - 100 μ m	40 - 400 / 20 - 100 μ m
Minimum reading	0.1 μ m	0.1 μ m

* PC is optional

System Configuration

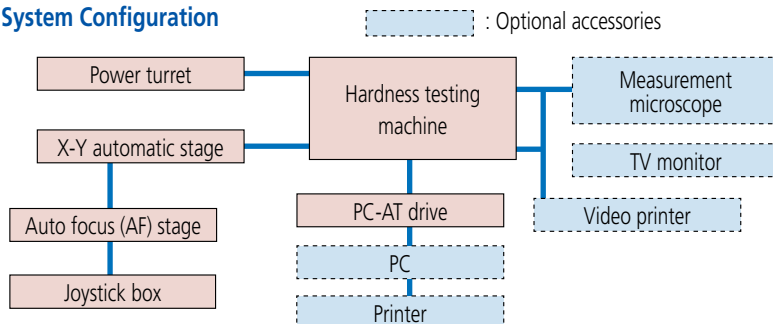

Technical Data

Automatic indication detection
 Detecting reproducibility: $\pm 0.5\%$ (0.1 μ m)
 Detecting method: Quadratic curve regression method
 Detecting time: 0.3 seconds
 Detecting minimum unit: 0.1 μ m
 Manual measurement function: Measurement method with video line
 X-Y automatic stage
 Stage area: 130 x 130mm
 Movement range: 50 x 50mm
 Minimum pitch: 1 μ m
 Software function
 Patterned measurement: Line, staggered, 3-point staggered, matrix, circle, arc, random
 Teaching measurement pattern setting
 Hardness calculation function
 Hardness conversion function
 OK/NG judgment
 Analysis software function:
 Device condition display
 Measurement data display
 Statistical calculation
 Graph display
 Dimensions (W x D x H) / Mass
 AAV-503 / AAV-504: 665 x 516 x 1000mm / 91kg

Optional Accessory

PC System

MZT-500

SERIES 810 — Micro Zone Test System

- Test data
You can obtain the indentation factor, which is related to the hardness value (partially) shown in Martens hardness test (ISO14577) and Young's modulus. Deformation characteristics in the load, dwell, and unload phases are also obtainable for use in determining properties of the specimen material.
- Hardness tests such as Vickers and Knoop hardness tests are supported. (MZT-512 and 522 only)
- The balance lever vibration isolation mechanism reduces the effect of external vibrations on measurements.
- The impression position precision is $\pm 0.5\text{mm}$ or less.
- Material characteristics evaluation of micro powder is available.
- Indenter indentation depth can be measured up to a maximum of 20mm with a measurement resolution of 0.1nm.
- Test force between 0.098mN and 980.7mN can be applied electromagnetically for evaluation of material properties in submicroscopic areas.
- Field-compatible form with cover for protection against dust and wind.

When it comes to evaluating mechanical properties of ultra-small regions of ultra-fine specimens, the MZT-500 Series are most powerful in the fields of research and development and quality control. The MZT-500 can evaluate mechanical properties, which the conventional hardness

testing machines for fine specimens cannot measure, such as: various CVD and PVD-deposited or generated films, including ion-plated films; hardness of ultra-fine cross-sections; bonding mechanical properties; and wear mechanical properties of carbon fiber, glass fiber, whisker, etc.

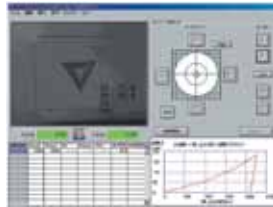

SPECIFICATIONS

Model No.	MZT-511	MZT-512	MZT-521	MZT-522
Order No.	810-809A	810-810A	810-811A	810-812A
Basic system	✓	✓	✓	✓
Data analysis / control device	✓	✓	✓	✓
Video line measurement software	—	✓	—	✓
Automatic multi-point measurement device	—	—	✓	✓

Test force loading device	Test force range	0.098 to 980.7mN
	Control resolution	0.916 μ N
	Loading speed	0.1 to 100mN/s
Indenter indentation depth measurement device	Measurement range	0 to 20 μ m
	Measurement minimum unit	0.1nm
Indenter	Type	Bercovici triangular pyramid indenter
	Camera	1/3 inch black and white (410,000 pixels)
Sample surface observation device	Monitor	9 inch black and white
	Objective (monitor magnification)	100X (2600X), 10X (260X)
	Maximum dimension	90mm
Specimen dimensions	Maximum depth	90mm (From the center of the indenter axis)
	Test type	Indenter indentation test (with an preliminary test force)
Indenter indentation test (without an preliminary test force)		
Indentation depth setting test, continuous indenter indentation test, repeated indenter indentation test		

HV-112 / 113 / 114 / 115

SERIES 810 — Vickers Hardness Testing Machines

FEATURES

- A wide range of test forces from 1.961N to 490.3N* (.2kgf - 50kgf) is available for measuring a wide variety of specimens. The load duration can be set in 1sec increments between 5 and 99sec. The minimum reading of indentation is 0.1µm. It allows small indentations to be measured with high precision.

Function: Control unit

- Back-lit LCD graphic display for Indentation size (D1 and D2), Hardness value and scale, Number of measurement point Test conditions (HV / HK indenter type, test force, load duration), GO / ±NG tolerance judgment, Cylindrical and spherical surface compensation and offset
- Remote control of power turret
- Conversion to other hardness scales
- Statistical processing



Technical Data

- Motorized lens turret
- Adjustable loading rate

HV-112, HV-114



HV-113, HV-115



SPECIFICATIONS

Model	HV112	HV113	HV114	HV115
Order No.	810-163A	810-981A	810-165A	810-985A
Test force	1.961N (0.2kgf), 2.942N (0.3kgf), 4.903N (0.5kgf), 9.807N (1kgf), 24.51N (2.5kgf), 49.03N (5kgf), 98.07N (10kgf), 196.1N (20kgf)		9.807N (1kgf), 19.61N (2kgf), 29.42N (3kgf), 49.03N (5kgf), 98.07N (10kgf), 196.1N (20kgf), 294.2N (30kgf), 490.3N (50kgf)	
Test force selection	Dial			
Loading accuracy	±1%			
Load control	50 - 100µ/s Automatic (loading, duration, unloading) Automatic			
Load rate	5~99 sec.			
Objective lenses	10X, 20X			
Measuring microscope Total magnification	100X / 200X		100X / 200X	—
Measuring range	350, 700µm	—	350, 700mm	—
Minimum reading	0.1µm			
Video monitor Camera	—	CCD	—	CCD
Display	—	9" monochrome CRT	—	9" monochrome CRT
Total magnification	—	250X, 500X	—	250X, 500x
Monitoring range	—	520 x 670µm, 260 x 330µm	—	520 x 670µm, 260 x 330µm
Measuring range	—	410 x 570µm, 200 x 280µm	—	410 x 570µm, 200 x 280µm
Display Function	Conversion: Hard: TENS, HS, HBS, HR15N, HR30N, HR45N, HRA, HRD, HRC, HK, HV, Soft: TENS, HR15T, HR30T, HR45T, HRA, HRF, HRB, HRG, HK, HV, Statistical list; N, Max., Min., Average, Range, High, Low, Good, Over, Under, SD(n-1), SD(n-1), SD(n) OK/NG Judgement, Curve correction; 0.01 to 200.00mm			
Specimen Maximum height	8.07" (205mm) or Flat anvil			
Maximum depth	6.7" (170mm) from center of indenter shaft			
Optical path	2-way switchable (microscope/photograph)			
Output	SPC, RS-232C Centronics			
Power supply	120V AC (±10%) 60Hz			
Dimensions (WxDxH) Main Unit only	9.7" x 20.3" x 31.3" (245 x 515 x 770mm)			
Mass	110 lbs. (50kg)	121.4 lbs. (55.2kg)	110 lbs. (50kg)	121.4 lbs. (55.2kg)

* 7.48" (190mm) if using 50 x 50mm-travel XY stage (No. **810-012**).

Optional Accessories

See page K-11

Consumable Parts

810-087: Illumination lamp (1 pc.)

Optional Accessories

Micro-Vickers/Vickers Hardness Testing Machine

Clamping devices (Vises)

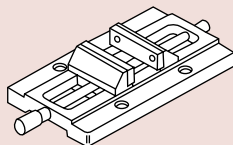

Vise

Max. opening: 3.94" (100mm)

810-017

Rotary Table

810-018

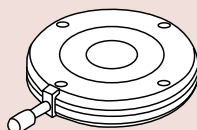

Round Tables



Dimensions: 8" (203mm)

810-037-7

Specimen (thin plate) Holder

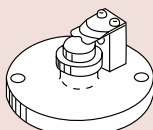

Secures a plate with a thickness of .197" (5mm) or less, or foil-like specimens.

810-013

Specimen (wire) Holder

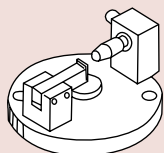

Used to horizontally secure a wire or needle specimen that has a diameter of .126" (3.2mm) or less.

810-014

Specimen (wire or ball) Holder

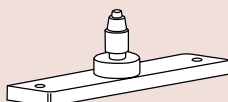

Used to vertically secure a wire or ball specimen that has a diameter of .126" (3.2mm) or less.

810-015

Test Blocks

Order No.	Description	Load
64BAA173	Vickers 100HV Test Block	100gf
64BAA174	Vickers 200HV Test Block	100gf
64BAA175	Vickers 300HV Test Block	100gf
64BAA176	Vickers 400HV Test Block	100gf
64BAA177	Vickers 500HV Test Block	100gf
64BAA178	Vickers 600HV Test Block	100gf
64BAA179	Vickers 700HV Test Block	100gf
64BAA180	Vickers 800HV Test Block	100gf
64BAA181	Vickers 900HV Test Block	100gf
64BAA182	Vickers 100HV Test Block	500gf
64BAA183	Vickers 200HV Test Block	500gf
64BAA184	Vickers 300HV Test Block	500gf
64BAA185	Vickers 400HV Test Block	500gf
64BAA186	Vickers 500HV Test Block	500gf
64BAA187	Vickers 600HV Test Block	500gf
64BAA188	Vickers 700HV Test Block	500gf
64BAA189	Vickers 800HV Test Block	500gf
64BAA190	Vickers 900HV Test Block	500gf
64BAA191	Vickers 100HV Test Block	1000gf
64BAA192	Vickers 200HV Test Block	1000gf
64BAA193	Vickers 300HV Test Block	1000gf
64BAA194	Vickers 400HV Test Block	1000gf
64BAA195	Vickers 500HV Test Block	1000gf
64BAA196	Vickers 600HV Test Block	1000gf
64BAA197	Vickers 700HV Test Block	1000gf
64BAA198	Vickers 800HV Test Block	1000gf
64BAA199	Vickers 900HV Test Block	1000gf
64BAA200	Knoop 200HK Test Block	100gf
64BAA201	Knoop 300HK Test Block	100gf
64BAA202	Knoop 400HK Test Block	100gf
64BAA203	Knoop 500HK Test Block	100gf
64BAA204	Knoop 600HK Test Block	100gf
64BAA205	Knoop 700HK Test Block	100gf
64BAA206	Knoop 800HK Test Block	100gf
64BAA207	Knoop 250HK Test Block	500gf
64BAA208	Knoop 300HK Test Block	500gf
64BAA209	Knoop 400HK Test Block	500gf
64BAA210	Knoop 500HK Test Block	500gf
64BAA211	Knoop 600HK Test Block	500gf
64BAA212	Knoop 700HK Test Block	500gf
64BAA213	Knoop 800HK Test Block	500gf
64BAA214	Knoop 250HK Test Block	1000gf
64BAA215	Knoop 300HK Test Block	1000gf
64BAA216	Knoop 400HK Test Block	1000gf
64BAA217	Knoop 500HK Test Block	1000gf
64BAA218	Knoop 600HK Test Block	1000gf
64BAA219	Knoop 700HK Test Block	1000gf
64BAA220	Knoop 800HK Test Block	1000gf

*other ranges available

Bulbs

Order No.	Description
513667	Bulb, 12v/50w, halogen double pin type, HM series with box style illuminators.
19BAA219	Bulb, 6v/2 0w, halogen double pin type, Later H series
19BAA095	Bulb, 6v/15w, halogen bayonet type, all E, G and early H series testers.

Indenters

Order No.	Type	Model
19BAA061	Knoop Indenter	H, HM Standard Series
19BAA058	Vickers Indenter	H, HM Standard Series
19BAA062	Knoop Indenter	MVK-H2, H3, HM114
19BAA059	Vickers Indenter	MVK-H2, H3, HM114
19BAA060	Vickers Indenter	HV, AVK-C Series

Universal Specimen Holder

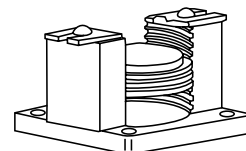

Used to secure a specimen, that has a measuring surface that is hard to stabilize, perpendicular to the indenter axis.

810-020

50x50mm travel stage

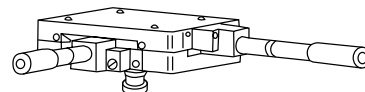

Dimensions: 4.92x4.92" (125x125mm)

Minimum reading: 0.01mm

810-012

Clamping devices (Vises)

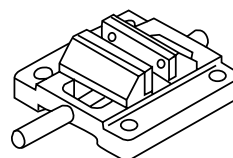

Vise

Max. opening: 1.77" (45mm)

Standard for the HM series.

810-016

Rockwell hardness scales

Preliminary test force: 98.07N (10kgf)

Scale	Indenter	Test force	Applications
A	Diamond	588.4N(60kgf)	Cemented carbide, thin steel plates case hardened steel
D		980.7N(150kgf)	
C		1471N(150kgf)	
F	1/16"	588.4N(60kgf)	Bearing metal, copper, annealed steel, brass, hard-drawn aluminum alloys beryllium copper, phosphor bronze
B	diameter	980.7N(100kgf)	
G	steel ball	1471N(150kgf)	
H	1/8"	588.4N(60kgf)	Bearing metal
E	diameter	980.7N(100kgf)	
K	steel ball	1471N(150kgf)	
L	1/4"	588.4N(60kgf)	Plastics, lead
M	diameter	980.7N(100kgf)	
P	steel ball	1471N(150kgf)	
R	1/2"	588.4N(60kgf)	Plastics
S	diameter	980.7N(100kgf)	
V	steel ball	1471N(150kgf)	

Hardness and Hardness Measurement

Hardness is a measure of resistance of a material to deformation when an external force or load is applied to the material. There are several hardness scales, which use different methods of applying force and quantifying the resistance to deformation. Hardness is closely correlated to other mechanical characteristics. It is, like many other mechanical characteristics, a relative value that has no fundamental quantity or absolute standard and is different from physical quantities such as length, time, and force. Because of this, hardness values are determined using a standard testing machine under standard conditions.

Today the most popular hardness scales are Brinell hardness (HB), Vickers hardness (HV), Rockwell and Rockwell superficial hardness (HR) and Knoop hardness (HK). Most hardness tests determine hardness from the area of the indentation made in a specimen by the indenter under a known load. The Brinell test was devised in Sweden, the Vickers test in the United Kingdom, and the other hardness tests in the United States. Although hardness is a relative value, Brinell, Vickers, and Knoop hardness are expressed in a unit of stress (1 kgf/mm² or 9.8MPa).

Rockwell Superficial hardness scales

Preliminary test force: 29.42N (3kgf)

Scale	Indenter	Test force	Applications
15N	Diamond	147.1N(15kgf)	Carburized layer, sintered
30N		294.2N(30kgf)	
45N		441.3N(45kgf)	
15T	1/16"	147.1N(15kgf)	Thin copper plates (brass, bronze), mild steel
30T	diameter	294.2N(30kgf)	
45T	steel ball	441.3N(45kgf)	
15W	1/8"	147.1N(15kgf)	Plastics, zinc, bearing alloys
30W	diameter	294.2N(30kgf)	
45W	steel ball	441.3N(45kgf)	
15X	1/4"	147.1N(15kgf)	Plastics, zinc, bearing alloys
30X	diameter	294.2N(30kgf)	
45X	steel ball	441.3N(45kgf)	
15Y	1/2"	147.1N(15kgf)	Plastics, zinc, bearing alloys
30Y	diameter	294.2N(30kgf)	
45Y	steel ball	441.3N(45kgf)	

Rockwell Hardness and Rockwell Superficial Hardness

In the Rockwell hardness and the Rockwell superficial hardness tests, a conical diamond indenter with a 120° angle and a radius of curvature of 0.2mm, or a steel or carbide ball indenter is pressed into the specimen. First, a preliminary test force is applied, then a total test force is applied, and then the test load is reduced to the preliminary test force. The hardness number is determined from the difference, h , of the indentation depth of the indenter between the first and second applications of the preliminary test force.

The Rockwell hardness test uses a preliminary load of 10kgf, and the Rockwell superficial hardness test uses a preliminary test force of 3kgf. The Rockwell and Rockwell superficial hardness have multiple scales to indicate specific combinations of the indenter type, test force, and formula to obtain the hardness. A unique symbol is given to each scale.

HR-521 / 523

SERIES 810 — Rockwell Type Hardness Testing Machines

Technical Data

Preliminary test force: 29.42N, 98.07N
 Test force
 Rockwell superficial: 147.1, 294.2, 441.3N
 Rockwell: 588.4, 980.7, 1471N
 Brinell*: 61.29, 98.07, 153.2, 245.2, 294.2, 306.4, 612.9, 980.7, 1226, 1839N

Test force setting: By control unit
 Load control: Automatic
 (loading, duration, unloading)
 Load duration: 0s - 120s (1s increments)
 Max. specimen height: 205mm (for standard flat anvil)
 Max. specimen depth: 150mm
 (from the center of indenter shaft)
 Stage elevation: Manual or power drive
 Control unit: Sheetswitch type or touch screen type
 Data output: RS-232C, Digimatic code (SPC) and Centronics
 Power supply: 120V AC, 50/60Hz
 Dimensions (W x D x H)
 Main unit: 250 x 670 x 605mm
 Control unit: 165 x 260 x 105mm

Optional Accessories: See page K-15, 16

Various shapes of specimen can be measured.
(Nose-type indenter axis mechanism has been adopted)
 The nose-type indenter mechanism allows measurement of pipe samples as well as the top surface of a flat sample.

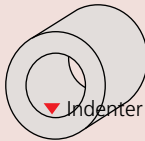
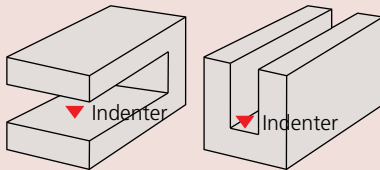

Function: Touch screen type

- Touch screen operation with a back-lit LCD graphic display.
- Remote selection of the test force linked to the hardness scale selection.
- Choice of message language in English, German, French, Spanish, Italian and Japanese for user friendly operation.
- Cylindrical and spherical surface compensation.
- Data offset
- Conversion to other hardness scales.
- Powerful statistical processing with flexible data point editing and 1024 data memory.
- Measured data editing
- OK/±NG tolerance judgment.
- Statistical processing, histogram and x-R chart

FEATURES

- Multiple test force generation for Rockwell, Rockwell Superficial and Brinell hardness.
- Dolphin-nose indenter arm for easy reach of interior (min. $\varnothing 40\text{mm}/\varnothing 22\text{mm}^*$) and exterior surfaces.
*When using an optional diamond indenter (19BAA292).
- Real time electronic test force control for accurate loading. This perfectly eliminates load force overshooting.
- Indenter escape function for continuous testing at fixed table position. This eliminates instability caused by the table retraction.
- Auto-stop elevation table and automatic preliminary test force loading to provide stable test force generation.



SPECIFICATIONS

Model	HR-521	HR-523
Order No.	810-204-03A	810-202-03A
Preliminary Test Force	29.42N (3kgf), 98.07N (10kgf)	
Test Force	Rockwell: 588.4N (60kgf), 980.7N (100kgf), 1471N (150kgf) Rockwell Superficial: 147.1N (15kgf), 294.2N (30kgf), 441.3N (45kgf)	
Force Control	Automatic control (unloading/duration/unloading) with closed loop feed back	
Console/Display Unit	Touch screen operation with back-lit LCD graphic display	
Test Force Selection	By touch screen	
Table up/down drive	Manual (w/Auto-brake mechanism)	Power-Drive (for full-automatic measurement)
Load Duration	0 to 120 sec. (1 sec. step)	
Maximum Specimen Height	Height: 205mm Depth: 150mm from center of indenter shaft	
Display Indication Functions	Hardness value, Converted hardness value, Test conditions, OK/NG tolerance judgement, statistical processing result Rockwell/Rockwell superficial hardness testing. Continuous testing. Cylindrical/spherical surface compensation, data offset Hardness conversion (HV, HK, HRA/B/C/D/F/G/15T/30T/45T/15N/30N/45N, HS, HB, HBW, tensile strength) OK/±NG tolerance judgement, measured data editing, data memory (max 1024 data) SPC calculation (No. of data, max/min/mean values, range, upper/lower limit values, standard deviation, No. of passing/defective) Histogram, x-R chart	
Data Output	RS-232C, SPC, Centronics	
Dimensions (W x D x H)	9.84" x 26.38" x 23.82" (250 x 670 x 605mm)	
Mass	60kg	

AR-20, ARK-600 / 601, ATK-600 / 601

SERIES 810 — Rockwell/Rockwell Superficial Hardness Testing Machine

FEATURES:

- Economy type Rockwell hardness testing machines.
- Diamond indenter (HRA, HRD, HRC) and 1/16" diameter steel ball indenter (HRF, HRB, HRG) are provided.
- The dial indicator can be zero-set automatically, allowing the preliminary test load to be applied with the table elevation wheel only.
- Test load selection can be made with wheel. (AR-20)



ATK-600



AR-20

Technical Data

Preliminary test force: 29.42N*, 98.07N
 Test force
 Rockwell superficial*: 147.1, 294.2, 441.3N
 Rockwell: 588.4, 980.7, 1471N
 Test force setting: By dial
 Load control: Automatic (loading, duration, unloading)
 Anvil: Flat (ø64mm)
 Max. specimen height: 140mm
 Max. specimen depth: 122mm (from the center of indenter shaft)
 Stage elevation: Manual
 Data output**: RS-232C, Digimatic code (SPC)
 Power supply: 120V AC, 50/60Hz
 *ATK-600 only
 **ARK-600 and ATK-600 only

Optional Accessories

See page K-15 & K-16

SPECIFICATIONS

Model	AR-20	ARK-600	ARK-601	ATK-600	ATK-601
Order No.	810-201-01A	810-218-01A	810-220-01A	810-257-01A	810-258-01A
Preliminary test force	98.07N (10kgf)			98.07N (10kgf), 29.42 (3kgf)	
Test force	588.4N (60kgf), 980.7N (100kgf), 1471N (150kgf)			147.1N(15kgf), 294.2N(30kgf), 441.3N(45kgf), 588.4N (60kgf), 980.7N (100kgf), 1471N (150kgf)	
Table up/down drive	Manual (with Loading Navigator)				
Load control	Automatic (loading, duration, unloading)				
Load duration	Automatic (3s to 5.5s) or manual				
Display	Dial	LED (4-digit)			
Hardness increment	0.5	0.1 (for each scale)		0.1 (for Rockwell each scale), 0.2 Rockwell Superficial (for each scale)	
Specimen Maximum height	5.51" (140mm) on Flat Anvil 5.91" (150mm)* on Round Table	12.60" (320mm) on Flat Anvil 13.00" (330mm)* on Round Table	5.51" (140mm) on Flat Anvil 5.91" (150mm)* on Round Table	11.02" (280mm) on Flat Anvil 11.42" (290mm)* on Round Table	
Maximum depth	4.8" (122mm) from center of indenter shaft				
Output	RS-232C, SPC				
Power supply	120V AC (±10%), 60Hz				
Power consumption	30VA				
Dimensions (W x D x H)	8.27 x 19.13 x 26.77" (210 x 486 x 680mm)	8.27 x 19.13 x 33.86" (210 x 486 x 860mm)	8.27 x 19.13 x 28.35" (210 x 486 x 720mm)	8.27 x 19.13 x 33.86" (210 x 486 x 860mm)	
Mass	88 lbs. (40kg)	99 lbs. (45kg)	93 lbs. (42kg)	99 lbs. (47kg)	

* Minimum height: .39" (10mm)

Optional Accessories

For Rockwell/Rockwell Superficial Type Hardness Testing machine



Calibration Set

Order No.	Order No.
64BAA241	64BAA242
C Scale Set	B Scale Set
Test Blocks	Test Blocks
64BAA125	64BAA126
64BAA124	64BAA132
64BAA158	64BAA135
Indenter	Indenter
64BAA072	64BAA078
Order No.	Order No.
64BAA243	64BAA244
30N Scale Set	30T Scale Set
Test Blocks	Test Blocks
64BAA128	64BAA129
64BAA165	64BAA140
64BAA167	64BAA130
Indenter	Indenter
64BAA073	64BAA078

Rockwell Type Diamond Indenters

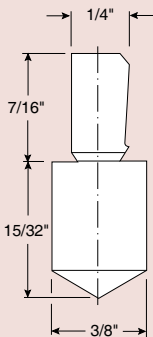

Order No.	Scale
64BAA072	C
64BAA073	N
64BAA086	A
64BAA071	C & N

Order No.	Hardness
64BAA159	HRA81/86 Rockwell Test Block
64BAA160	HRA75/79 Rockwell Test Block
64BAA161	HRA70/73 Rockwell Test Block
64BAA162	HRA65/68 Rockwell Test Block
64BAA163	HRA60/62 Rockwell Test Block

64BAA249	HRBW95/100 Rockwell Test Block
64BAA126	HRBW90/95 Rockwell Test Block
64BAA131	HRBW80/85 Rockwell Test Block
64BAA132	HRBW70/75 Rockwell Test Block
64BAA133	HRBW60/65 Rockwell Test Block
64BAA134	HRBW50/55 Rockwell Test Block
64BAA135	HRBW40/45 Rockwell Test Block
64BAA127	HRBW30/35 Rockwell Test Block
64BAA136	HRBW20/25 Rockwell Test Block
64BAA137	HRBW10/15 Rockwell Test Block
64BAA138	HRBW0/5 Rockwell Test Block

64BAA125	HRC60/65 Rockwell Test Block
64BAA157	HRC50/55 Rockwell Test Block
64BAA124	HRC40/45 Rockwell Test Block
64BAA123	HRC30/35 Rockwell Test Block
64BAA158	HRC20/25 Rockwell Test Block

Order No.	Hardness
64BAA129	HR30T74/79 Rockwell Test Block
64BAA139	HR30T70/73 Rockwell Test Block
64BAA140	HR30T63/67 Rockwell Test Block
64BAA141	HR30T56/60 Rockwell Test Block
64BAA142	HR30T49/53 Rockwell Test Block
64BAA130	HR30T43/47 Rockwell Test Block
64BAA143	HR30T36/39 Rockwell Test Block
64BAA144	HR30T29/33 Rockwell Test Block
64BAA145	HR30T22/26 Rockwell Test Block
64BAA146	HR30T15/18 Rockwell Test Block

64BAA147	HR15T90/92 Rockwell Test Block
64BAA148	HR15T86/69 Rockwell Test Block
64BAA149	HR15T83/85 Rockwell Test Block
64BAA150	HR15T80/82 Rockwell Test Block
64BAA151	HR15T77/79 Rockwell Test Block
64BAA152	HR15T72/74 Rockwell Test Block
64BAA153	HR15T70/72 Rockwell Test Block
64BAA154	HR15T68/69 Rockwell Test Block
64BAA155	HR15T64/66 Rockwell Test Block
64BAA156	HR15T61/63 Rockwell Test Block

Order No.	Hardness
64BAA222	HR45N65/70 Rockwell Test Block
64BAA223	HR45N55/60 Rockwell Test Block
64BAA224	HR45N45/50 Rockwell Test Block
64BAA225	HR45N35/40 Rockwell Test Block
64BAA226	HR45N25/30 Rockwell Test Block

64BAA128	HR30N77/82 Rockwell Test Block
64BAA164	HR30N68/73 Rockwell Test Block
64BAA165	HR30N59/64 Rockwell Test Block
64BAA166	HR30N50/55 Rockwell Test Block
64BAA167	HR30N40/45 Rockwell Test Block

64BAA168	HR15N90/93 Rockwell Test Block
64BAA169	HR15N85/88 Rockwell Test Block
64BAA170	HR15N80/83 Rockwell Test Block
64BAA171	HR15N75/77 Rockwell Test Block
64BAA172	HR15N69/72 Rockwell Test Block

Carbide Ball Indenters

Order No.	Description
19BAA515	1/16" Carbide ball indenter
19BAA504	1/8" Carbide ball indenter
19BAA505	1/4" Carbide ball indenter
19BAA506	1/2" Carbide ball indenter
19BAA507	1/16" Carbide ball (1pc.)
19BAA508	1/8" Carbide ball (1pc.)
19BAA509	1/4" Carbide ball (1pc.)
19BAA510	1/2" Carbide ball (1pc.)

Steel Ball Indenters

Order No.	Description
64BAA074	1/16" diameter steel ball indenter
19BAA078	1/16" diameter steel ball indenter (auto-discrimination type)
64BAA075	1/8" diameter steel ball indenter
19BAA079	1/8" diameter steel ball indenter (auto-discrimination type)
64BAA076	1/4" diameter steel ball indenter
19BAA080	1/4" diameter steel ball indenter (auto-discrimination type)
64BAA077	1/2" diameter steel ball indenter
19BAA081	1/2" diameter steel ball indenter (auto-discrimination type)
64BAA082	1/16" diameter spare steel ball (10 pcs)
64BAA083	1/8" diameter spare steel ball (10 pcs)
64BAA084	1/4" diameter spare steel ball (10 pcs)
64BAA085	1/2" diameter spare steel ball (10 pcs)

Optional Accessories

For Rockwell/Rockwell Superficial Type Hardness Testing machine

Flat anvil

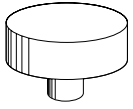

Diameter: 2.5" (64mm)

810-039-7

Diameter: 1.5" (38mm)

810-039-8

Round Table

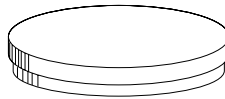

Diameter: 8" (203mm)

810-037-7

Spot anvils

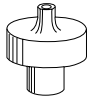

Diameter: .25" (6.4mm)

Height: .88" (22mm)

810-044-7



Diamond-tipped type for
Rockwell superficial hardness measurement

810-030-7

V-anvils



Diameter: 1.5" (38mm)

Groove width: .38" (9.7mm)

810-041-7

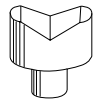

Diameter: 1.5" (38mm)

Groove width: 1.5" (38mm)

810-040-7



Diameter: 3/8" (9.7mm)

Groove width: .38" (9.7mm)

810-042-7

Adjustable support

Adjustable height:
13 to 18.5" (330 to 470mm)
Used to mount a V-anvil.

810-028-7

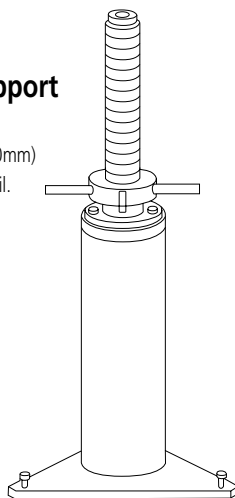

264-504-5A



937386



Hardmatic HH-411

SERIES 810 — Impact Type Hardness Testing Unit

Technical Data

Impactor:	Impact hammer with integrated detector and carbide-ball tip (D type: conforming to ASTM A 956)
Display unit:	7-segment LCD
Functions:	Auto angle compensation, Offset, OK/NG judgment, Hardness scale conversion Data storage (1800 data entries) Statistical analysis (Average, Maximum, Minimum, Dispersion) Auto sleep function Impact counter display function
Testable workpiece	
Thickness:	Minimum 5mm or more
Mass:	5kg or more in mass
Test points:	5mm or more from the edge of the sample, 3mm or more to each of the tested points.
Surface roughness:	Ra 10µm or less
Power supply:	Alkaline AA battery 2pcs or optional AC adapter (battery life: 70 hours)

Standard Accessories

19BAA265	Test Block HLD800
810-291	Display Unit
810-287	Detector
19BAA460	Cable
	Battery AA (Alkaline) 2pcs.

Optional Accessories

264-504-5A:	Digimatic Mini-Processor DP-1VR
937387:	Connecting cable for
09EAA082:	Printer paper (10 rolls/set)
810-622A:	Thermal printer DUP-414
19BAA262:	Thermal printer connecting cable
19BAA157:	Thermal printer paper
19BAA238:	RS-232C connecting cable for PC
526688A:	AC adapter of display unit
19BAA243:	Hardness test block (880HLD)
19BAA244:	Hardness test block (830HLD)
19BAA245:	Hardness test block (730HLD)
19BAA246:	Hardness test block (620HLD)
19BAA247:	Hardness test block (520HLD)
19BAA248:	Support ring for convex surface of cylinder (R10 - R20)
19BAA249:	Support ring for convex surface of cylinder (R14 - R20)
19BAA250:	Support ring for convex surface of sphere (R10 - R27.5)
19BAA251:	Support ring for concave surface of sphere (R13.5 - R20)
19BAA457:	Carbide ball for D, DC, D+15 type impactors
19BAA458:	Ball shaft for DL type impactor
810-287:	D type impactor UD-411
810-288:	DC type impactor UD-412
810-289:	D+15 type impactor UD-413
810-290:	DL type impactor UD-414

HH-411 is a rebound type portable hardness tester for metal with a compact body and high operability. It allows anyone to perform hardness testing easily at the touch of a key, so it can be used widely on various components in the field.



810-298: ASTM standard
Including the display unit, D type impactor (810-287) and carbide ball (19BAA457).

SPECIFICATIONS

Model	HH-411		
Order No.	810-298		
Hardness Range	L-Value (ASTM A956)		
Detector	Input device D (carbide ball)		
Display	Hardness	Range	Resolution
	HL	1-999 HL	1 HL
	HV	43-950 HV	1 HV
	HB	20-894 HB	1 HB
	HRC	19.3-68.2 HRC	0.1 HRC
	HRB	13.5 - 101.7 HRB	0.1 HRB
	HS	13.2 - 99.3 HS	0.1 HS
	HTN	499 - 1996 Mpa	1 Mpa
Functions	Conversions: HL, HV, HB, HRC, HRB, HS, HTN Judgment: OK/NG Offsetting Memory: 1,800 data		
Indentation Direction	Any direction		
Output	RS-232C, SPC		
Power supply	Alkaline AA Battery 2pcs.		
Dimensions	Detector: (Dia. X H) 1.10" x 6.89" (28 x 175mm) Display: (W x D x H) 2.76" x 4.33" x 1.38" (70 x 110 x 35mm)		
Mass	Detector: .26lbs (120g) Display: .44lbs (200g)		

Impactors (Optional accessories)

Various impactors can be connected to the display unit.



810-288
Use for inner walls of cylinders.
The grip is short to allow easy positioning within a cylinder.



810-290
Use for gear teeth, welded corners, etc.



810-289
Use for concave workpieces such as gear teeth, ball bearing races, etc.

Hardmatic HH-300

SERIES 811 — Durometers for Rubber and Plastics Hardness Testing

FEATURES

Digital / Dial Durometers are suitable for testing the nature of the following materials — natural rubber, neoprene, polyesters, P.V.C., leather, Thiokol, nitrite rubber, wax, vinyl, cellulose acetates, glass polystyrene, etc.



SPECIFICATIONS

Order No.	Digital	811-330	811-336	811-336-01	811-332	881-338	811-338-01	811-334
	Dial	811-329	811-335	811-335-01	811-331	881-337	811-337-01	811-333
Model No.	Digital	HH-330	HH-336	HH-336-01	HH-332	HH-338	HH-338-01	HH-334
	Dial	HH-329	HH-335	HH-335-01	HH-331	HH-337	HH-337-01	HH-333
Scale		Shore E	Shore A			Shore D		
Applications		Soft Rubber, Sponge, Felt, Hard Foam, Winder	Natural rubber, soft elastomers, etc.			Hard elastomers, plastics, hard rubber, ebonite, etc.		
Resolution		0.5 (digital) or 1 (dial)				0.5 (digital) or 1 (dial)		
Range		HA: 10 - 90				HD: 20 - 90		
Standards	ASTM D 2240	—	✓	✓		✓	✓	
	ISO 868	—	✓	✓		✓	✓	
	ISO 7619	—	✓	✓		✓	✓	
	DIN 53 505	—	—	✓		—	✓	
	JIS K 6253	✓	✓	✓		✓	✓	
	JIS K 7215	—	✓	✓		✓	✓	
Pressure foot		44 x 18mm	44 x 18mm	ø18mm		44 x 18mm	ø18mm	
Spring force (mN)		WE=550+HE	WA=550+75HD (HA:Reading 10-90)			WD=444.5HD (HD:Reading 20-90)		
Indenter		Sphere (Tip diameter: 0.79mm)	Blunt taper (Tip diameter: 0.79mm)			Sharp point (Tip curvature: 0.1±0.01mm)		
Tip angle		35°±0.25°				30°±0.5°		
Indenter diameter		1.25mm						
Indenter protrusion		2.5mm						
Functions		Digital: Data hold, Zero -setting, SPC output, Power ON/OFF (Power supply: SR44 x 1 pc.) Analog Durometer: Peak retaining hand						
Type		Compact	Compact	Long-leg	Compact	Long-leg	Compact	Long-leg
Dimensions (WxDxH)	Digital	60 x 28.5 x 151	60 x 28.5 x 151mm		60 x 28.5 x 193mm	60 x 28.5 x 151mm		60 x 28.5 x 193mm
	Dial	56 x 33.5 x 144mm	56 x 33.5 x 144mm		56 x 33.5 x 186mm	56 x 33.5 x 144mm		56 x 33.5 x 186mm
Mass	Digital	290g	290g	310g	290g	310g	290g	310g
	Dial	300g	300g	320g	300g	320g	300g	320g

Technical Data

- Designed in accordance with the ASTM D 2240, ISO868, ISO 7619, DIN 53 505, JIS K 6253, and JIS K 7215 specifications.
- Units are available in both Shore A and Shore D scales, and will test a wide variety of applications.
- The Digital Durometer is provided with data hold function, permitting the operator to make an error-free reading on the LCD screen.
- The Dial Durometer is provided with a peak retaining hand for error-free reading.

Testing stand applications

These stands are used to mount Durometers. They allow constant-pressure hardness measurement by pressing the Durometer vertically on a workpiece.

- Anyone can perform repeatable hardness measurement due to fewer possibilities of human error and measurement variations.
- The supplied weights can be attached directly to a Durometer and allow constant-pressure hardness measurement of large samples for which a stand cannot be used.
- The supplied weights are used for calibrating the spring tension of Durometers.



Hardmatic HH-300

Test Block Set

Holding Bar

The holding bar is used to mount a Durometer on a drill press.

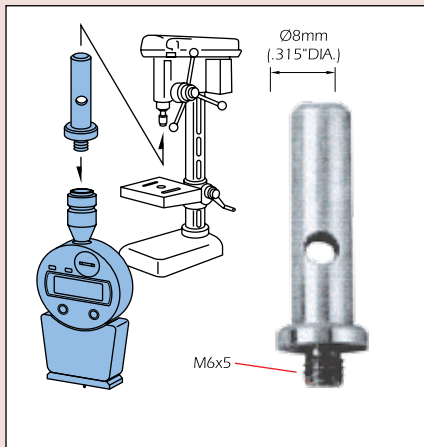

64AAA964



64AAA963



905693

811-332

19BAA406

Item No.	Description
19BAA180	Holding Bar
64AAA964	Calibration Set (Shore A Scale) Test Block 30* DURO (Blue) Test Block 60* DURO (Yellow) Test Block 90* DURO (Gray) Mahogany Box
64AAA590	Calibration Set (Shore D Scale) Test Block 20* DURO (Blue) Test Block 40* DURO (Gray) Test Block 80* DURO (Black)
64AAA962	"A" Scale Durometer Stand
64AAA794	"A" Scale Durometer Stand with Air Damper
64AAA796	Combination "D" & "A" Scale Durometer Stand
64AAA963	O-Ring Fixture Set 1/16", 3/32", 1/8", 3/16" and 1/4" O-Ring cross sections
19BAA406	Digimatic Miniprocessor with printer
905693	Connecting Cable 40" (1m) for Durometer and Digimatic Miniprocessor

* Values shown are nominal only. Test Block Size 2" x 2" x 1/4"

